

**GATE VALVE** **A**

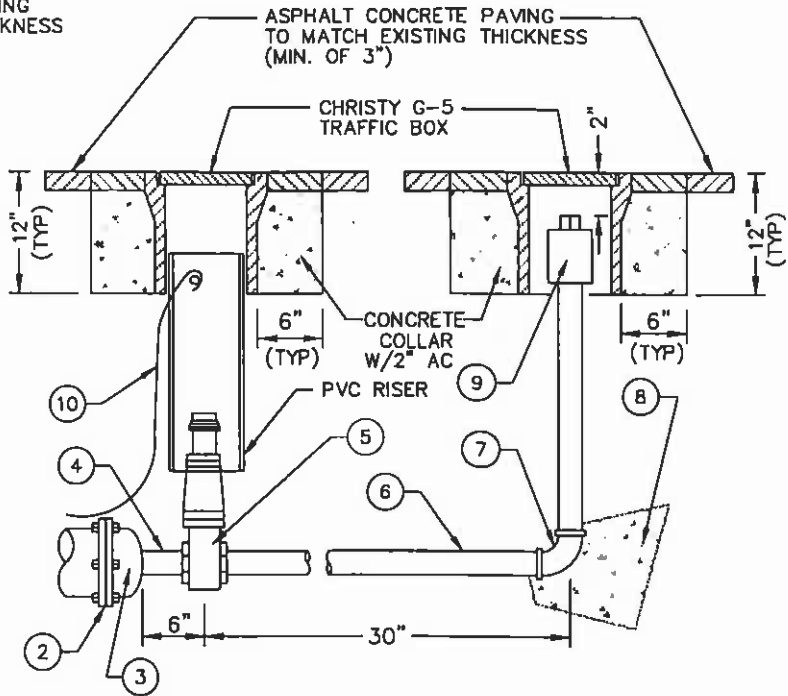

**BLOWOFF VALVE** **B**      **BLOWOFF RISER** **C**

**BLOWOFF ASSEMBLY**

- NOTES:**
- ① GATE VALVE SHALL BE FLANGED x MECHANICAL JOINT, RESILIENT SEAT TYPE, POLYWRAP.
  - ② APPROVED RESTRAINING GLAND AND BELL AND SPIGOT JOINT RESTRAINT. POLYWRAP. LENGTH OF JOINT RESTRAINT SHALL BE APPROVED BY THE CITY ENGINEER. OTHER METHODS OF THRUST RESTRAINT SHALL BE SUBMITTED AND APPROVED BY THE CITY ENGINEER PRIOR TO INSTALLATION.
  - ③ TAPPED CAP x 2 INCH IPS.
  - ④ 2 INCH BRASS NIPPLE.
  - ⑤ 2 INCH RESILIENT SEAT GATE VALVE.
  - ⑥ SCHEDULE 80 PVC.
  - ⑦ SCHEDULE 80 PVC 90 DEGREE BEND.
  - ⑧ CONCRETE THRUST BLOCK - MIN. 1 SQ. FT. BEARING AREA.
  - ⑨ 2 INCH BALL VALVE.
  - ⑩ TRACER WIRE AS PER CITY STANDARD (SEE DETAIL #513).
  - ⑪ PROVIDE EXTENSION IF OPERATING NUT EXCEEDS MAXIMUM OF FOUR (4) FEET FROM FINISHED GRADE. EXTENSION SHALL INCLUDE A STEADYING PLATE.

- A. FOR WATER MAINS 10 INCHES OR LESS IN DIAMETER, BLOWOFF SHALL BE 2 INCHES.
- B. FOR WATER MAINS 12 INCHES TO 16 INCHES IN DIAMETER THAT DO NOT EXCEED 200 FEET IN LENGTH, BLOWOFF SHALL BE 2 INCHES.
- C. ALL NUTS, BOLTS AND WASHERS ON FITTINGS SHALL BE STAINLESS STEEL TYPE 304.
- D. CONCRETE SHALL BE CLASS "A".
- E. ON WATER MAINS 20" OR GREATER, REDUCER MUST BE ECCENTRIC.
- F. CUL-DE-SAC INSTALLATION:
  - 1. USE STANDARD BLOWOFF ASSEMBLY (B) & (C).
  - 2. IF FIRE HYDRANT IS AT END OF LINE, NO BLOWOFF IS REQUIRED.
- G. END OF WATER MAIN INSTALLATIONS
  - 1. TO BE EXTENDED LATER: INSTALL GATE VALVE AND BLOWOFF RISER, (A) & (C).
  - 2. NOT TO BE EXTENDED: INSTALL BLOWOFF ASSEMBLY, (B) & (C).
  - 3. IF FIRE HYDRANT IS AT END OF LINE, NO BLOWOFF ASSEMBLY REQUIRED.
  - 4. NO SERVICES BEYOND GATE VALVE (A) UNLESS APPROVED BY THE CITY ENGINEER.

**THE CITY OF WEST SACRAMENTO - STANDARD DETAIL**

APPROVED BY: 	C-38733	3/31/05
CITY ENGINEER	P.E. NO.	DATE
REVISION:		
REVISION:		
REVISION:		
REVISION:		

TITLE:

**2" BLOWOFF ASSEMBLY**

STANDARD DETAIL #: 511

